

GC * & * ! \$' ! \$' ! \$! - +

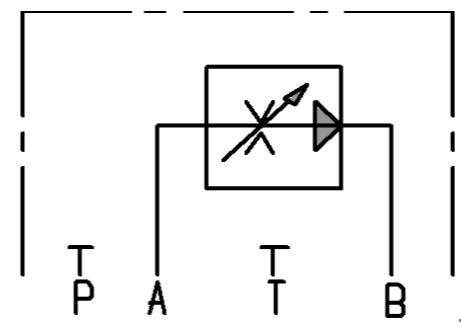

D'a U & \$ VUF
Ej Yb 6. \$ { % & # a b

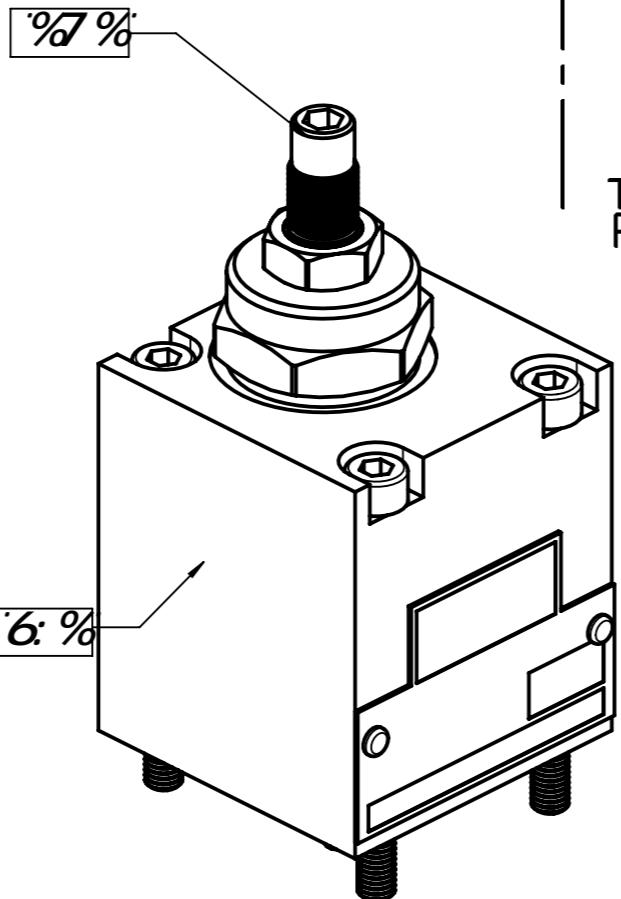
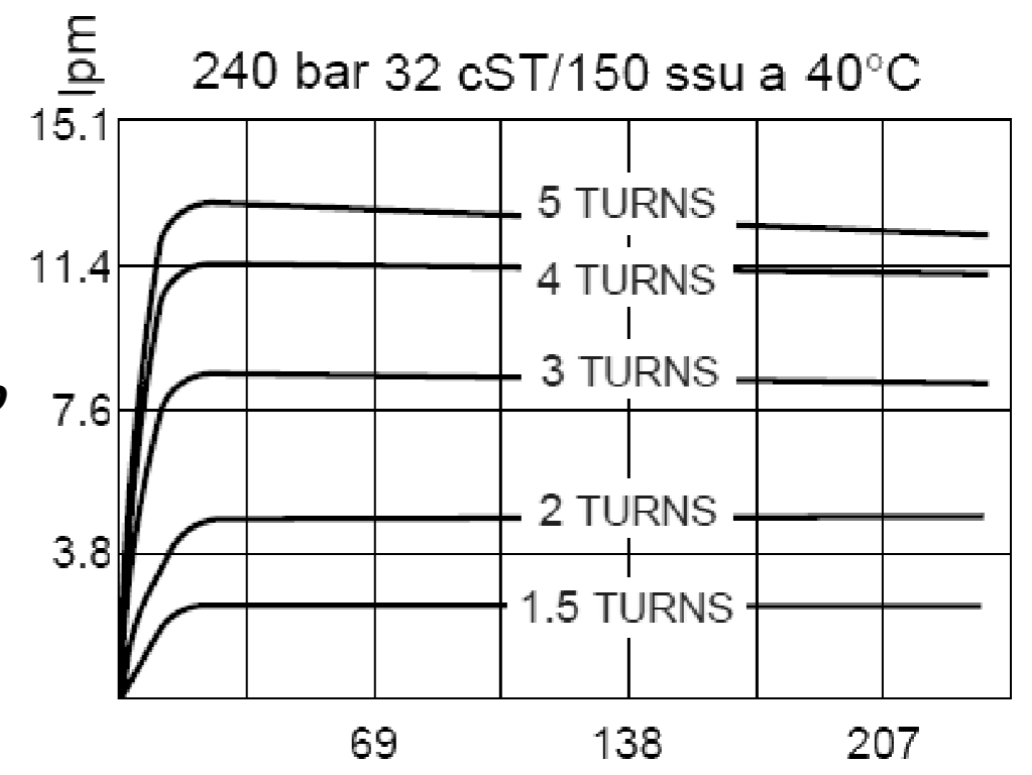

Ô^Á&@{ æ . & • æ^Á } ^Á@ æ^Á } { i i ^
æ c^æææc . i^æ c^ ^ . Á ~ ææ c^ ÁK

| | |
|--------------------|---------------------|
| Ôæ • ^ÁQ UÁ I € D | Fi Fi FH |
| Ø^ æ^ | P^ æ^ Á æ . i . æ^ |
| V^ {] . i . æ^ i^ | Ê € X Ô Á € I € X Ô |

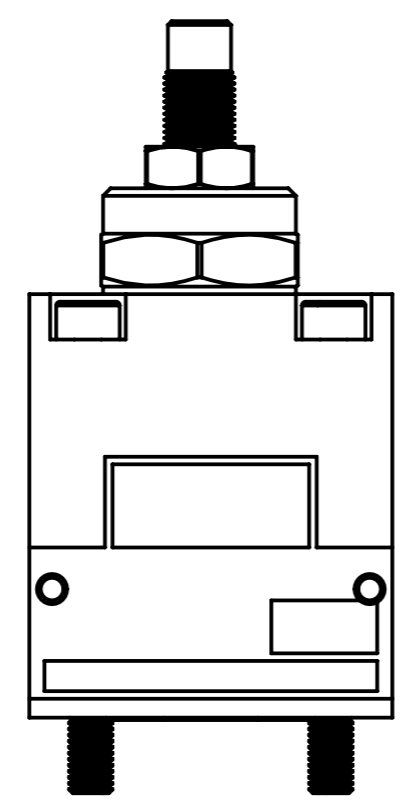
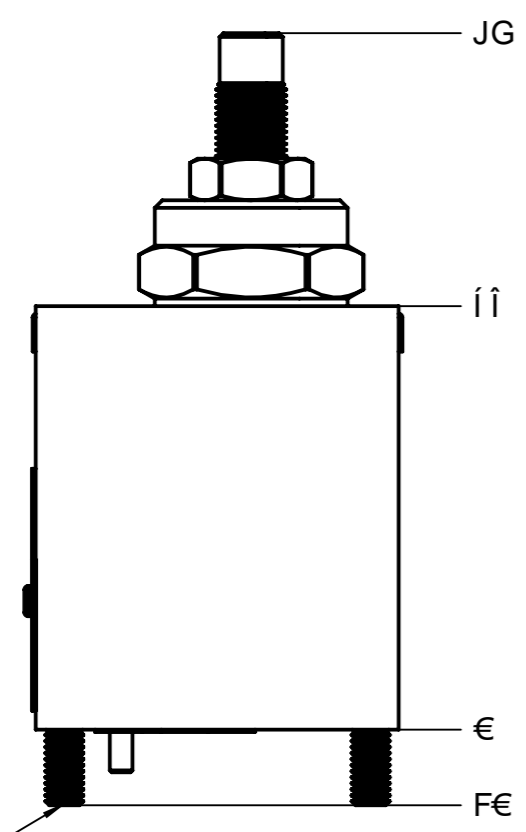

| REP. | NB. | DESIGNATION | REP.CAV. | Cs cartouche (Nm) |
|------|-----|---------------------|----------|-------------------|
| BF1 | 1 | BLOC D'ENTREE | | |
| 1C1 | 1 | FR10-33A-0-N | 1 | 34 |
| 1V1 | 4 | CHc M5x60 | | |
| 1J1 | 4 | JOINT CARRE 1722504 | | |

| | | | | |
|--|---------------|---|---------------------------|-----------------------------------|
| È | È | È | È | È |
| Qã&• Öæ• | | T äãæã } • | | X . i . äãæã } p » äã ~ ^ æ^ Xã æ |
| Ô[c^ Á æ • Á } . i . æ & • Á Á € Oj * i^ Á æ • Á } i . æ & • Á Á F » | | Le pr°sent document est la proprié° exclusive de FP HYDRAULIQUE . Il ne peut ²tre communiqué © des tiers ni utilis° ou reproduit sans autorisation | | |
| Ø&@ ^ | p » äã ~ ^ æ^ | Ö • • ä ... | X . i . äãæã } | |
| | F | • ^ i ç ^ i | i^ G BEGF €] æ T OY T OY | |
| T æã i^ Á ~ Á i ä æ ^ | | Viæã { ^ } c | | |
| Ö . • ä } æã } Á } • ^ { à ^ | | Ö . • ä } æã } Á . æã | | |
| PÜÖÁ ÒÒFGPÜZ | | ÒP ÒUT ÒÜÒT ÒP V UÒPÒT ÒE PUT ÒP ÒÖÖE/WÜÒ | | |
| | | FP HYDRAULIQUE BP9 - THYEZ - 74311 CLUSES CEDEX Tél. : 04 50 34 57 77 - Fax. : 04 50 34 04 20 | | |
| Qã&• A B C D E F G H J | | p » HGHEFE€€ | | |
| | | K L M N P Q R S T U V W | | |