

GC \* & ' ! \$ ' ! \$ ' ! \$ ! - +

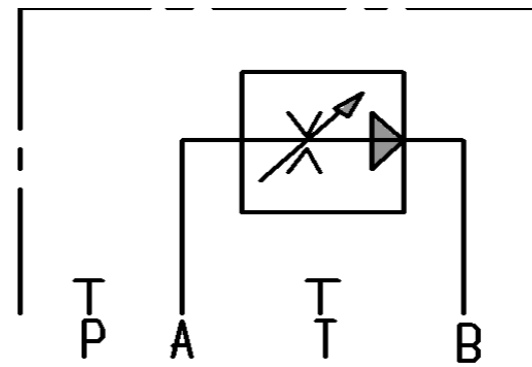

D'a U & \$ VUF  
Ej Yb 6. \$ { " \$ # b

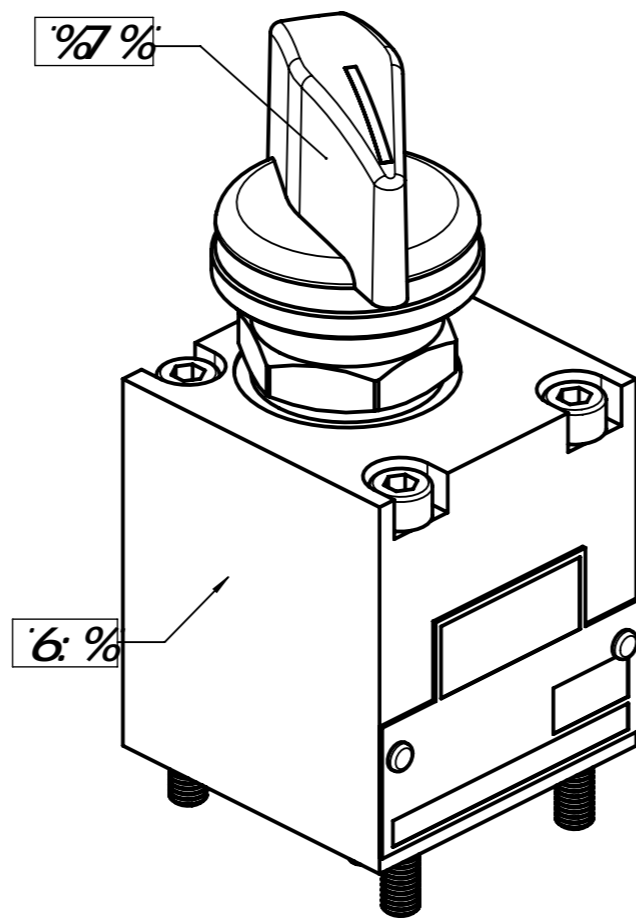
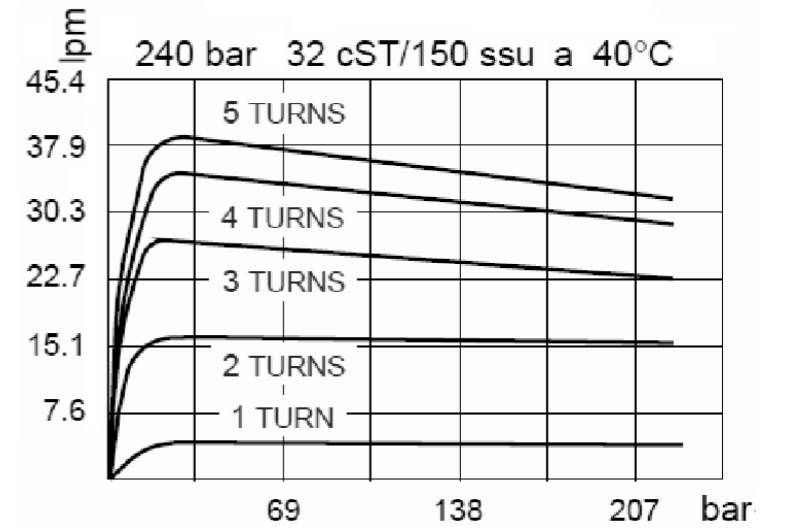

Ô^Á&@.{ æÁ..&^••ã^Á}^Á@ã^Á& } { ! { ^  
æ çÁ&æ&c.l.ã çã ^•Á^ çæ ç•ÁK

Ô æ•^ÁQÜUÁ I € I D	FÌ Æ I Æ H
Ø^ ã^	P^ ç^Á ç ..!æ^
V^ { ] ..!æç !^	Ë€»ÔÁÆËË €»Ô

REP. NB.	DESIGNATION	REP.CAV.	Cs cartouche (Nm)
BF1 1	BLOC D'ENTREE		
1C1 1	FR10-39-ESP-0-N-3087700	1	34
1V1 4	CHc M5x60		
1J1 4	JOINT CARRE 1722504		

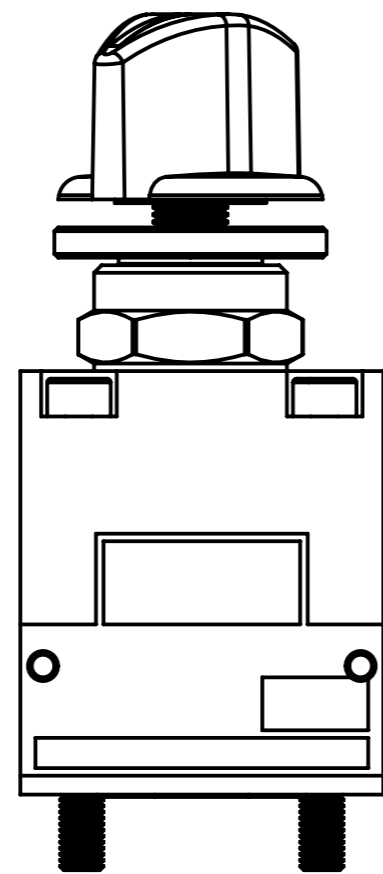
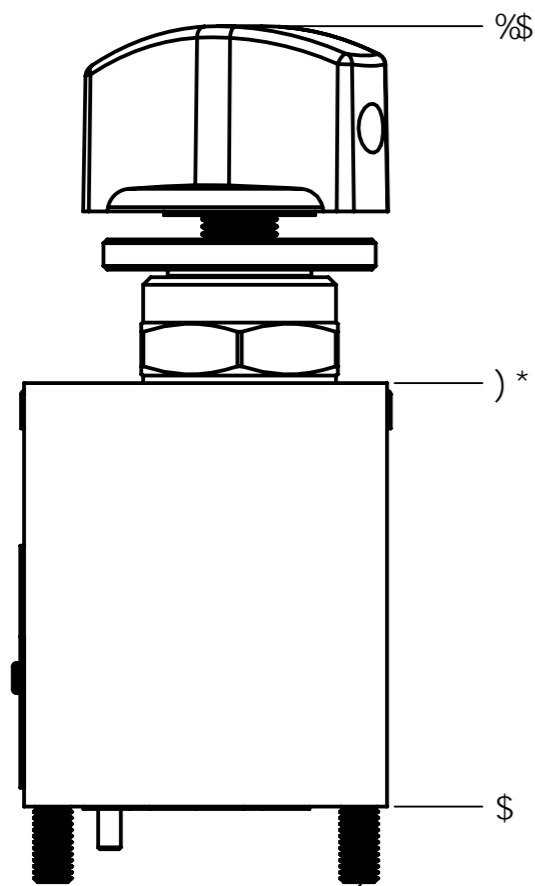

È	È	È	È	È
Qã&^	Öæ•	T   äã&ã } •	X..!ã&ã }	P»ãã^~^æ^
<p>Ô ç•Áæ ç.Á  ..!æ &amp;•ÁÆ Ë Ç ç•Áæ ç.Á  ..!æ &amp;•ÁÆ F»</p>		<p>Le pr°sent document est la proprié° exclusive de FP HYDRAULIQUE . Il ne peut ²tre communiqué © des tiers ni utilis° ou reproduit sans autorisation</p>		
Ø&@ ^	P»ãã^~^æ^	Ö••ã...	X..!ã&ã }	
⊕	F	•^!ç^!	^ G-EGF€   æ T ÇY	T ÇY
T æã^~^æ^		V!æç { ^} c		
Ö..ã } æ } Á } •^ ( à ^		Ö..ã } æ } Á..æã		
PÜÖÁ ÒÒFI PUY		ÒP ÒUT ÒÜÒT ÒP V UÒPÒT ÇE PUT ÒP ÒÖÇE/WÜÒ		
Qã&^		A B C D E F G H J		
P»		H F H € €		
		K L M N P Q R S T U V W		

