

D'a U & \$ VUF  
 Ej Yb 5. & ) `#a b  
 Ej Yb 6. \$ { %& `#a b

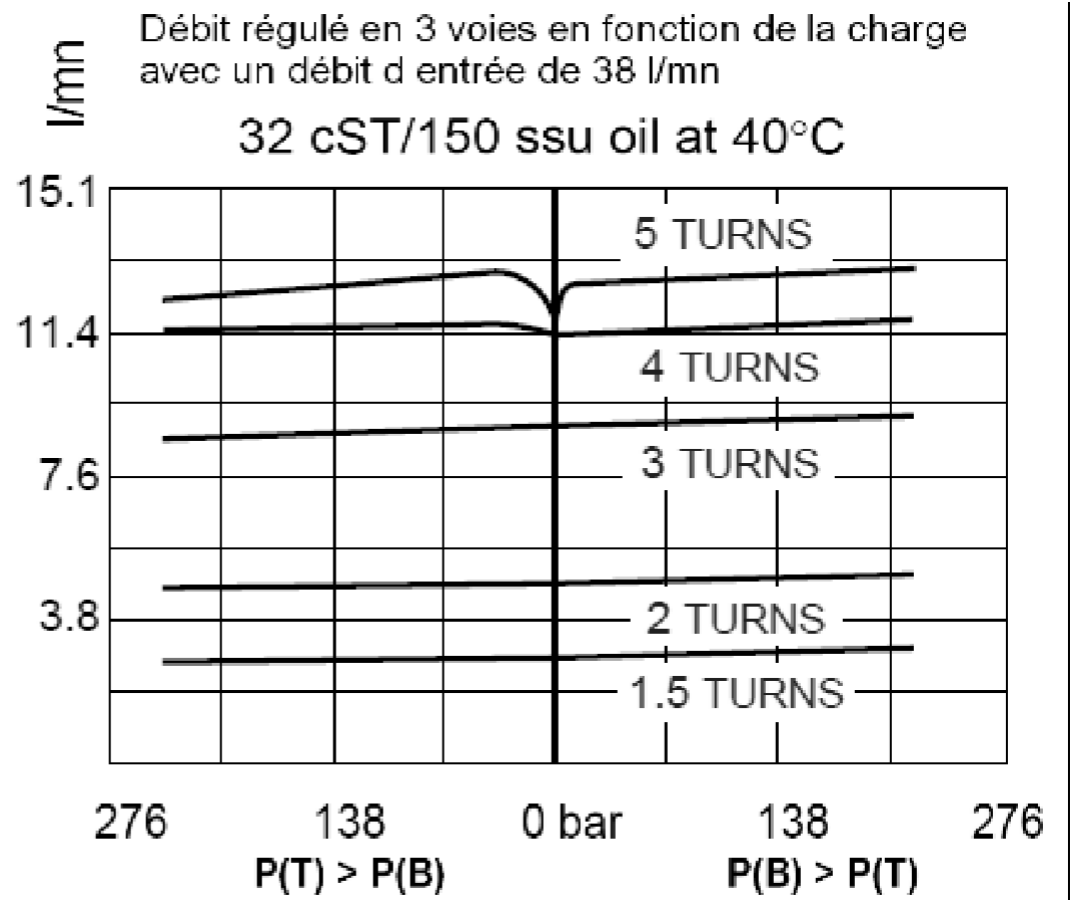
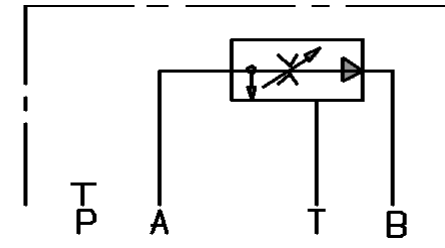

GC \* & ' ! \$ ' ! \$ ' ! \$ ! - +

Ô^Á&@{ æ . & • æ Á ^ Á @ æ Á } { i { ^  
 æ ç Å æ æ ç . i æ ç ^ . Á ^ æ ç ç . Å K

Ôæ • ^ Á Q U Á I € D	F i F i F H
Ø` æ ^	P` æ Á æ . i æ ^
V^ { ] . i æ i ^	Ê € X Ô Á É I € X Ô

REP.	NB.	DESIGNATION	REP.CAV.	Cs cartouche (Nm)
BF1	1	BLOC D'ENTREE		
1C1	1	FR10-33A-0-N	1	34
1V1	4	CHc M5x60		
1J1	4	JOINT CARRE 1722504		

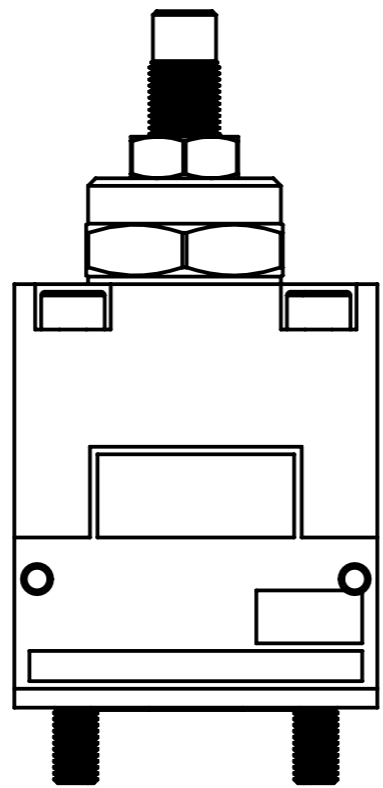
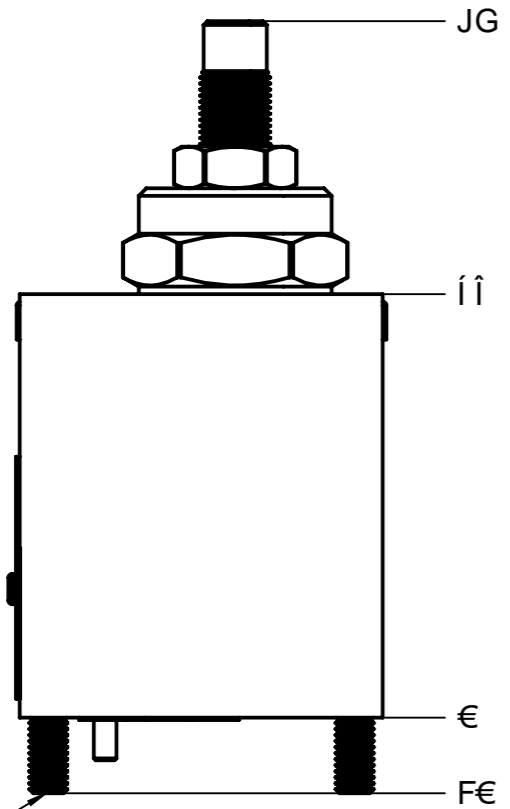

(1 %)

Le présent document est la propriété exclusive de FP HYDRAULIQUE. Il ne peut être communiqué à des tiers ni utilisé ou reproduit sans autorisation.

**FP HYDRAULIQUE**  
 BP9 - THYEZ - 74311 CLUSES CEDEX  
 Tél. : 04 50 34 57 77 - Fax. : 04 50 34 04 20

Q	A	B	C	D	E	F	G	H	J		
P	HFI HEE										
K	L	M	N	P	Q	R	S	T	U	V	W