

HNH

CLAPETS ANTI-RETOUR PILOTES PILOTED CHECK VALVES ENTSPERRBARE RÜCKSCHLAGVENTILE

Micro
Micro
Mikro

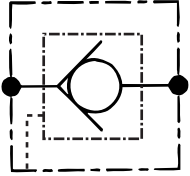

Montage Mounting Einbau	Rapport : <u>pression retenue</u> pression pilote Ratio : <u>restrain pressure</u> pilot pressure Verhältnis : <u>Haltdruck</u> Steuerdruck	P max Q max	Référence Part number Bestellnummer
-------------------------------	--	----------------	---

En ligne (banjo) In line (banjo) Rohranschluss(banjo)	4 : 1	Action directe Direct action Direkte Aktion	200 bar	HNH	2DL	a	*
---	-------	---	---------	-----	-----	---	---

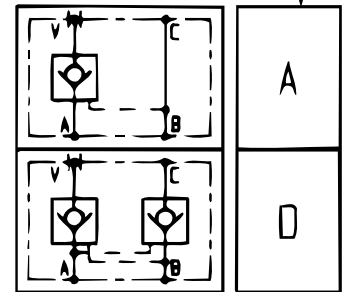

a	Matière joint Seal materials Dichtungswerkstoffe
H	Nitrile (standard)
V	Viton

■ sur demande
on request
auf Anfrage

HNH 2DL...	
Poids Weight Gewicht	0.5 kg

Perte de charge
Viscosité 30 cst

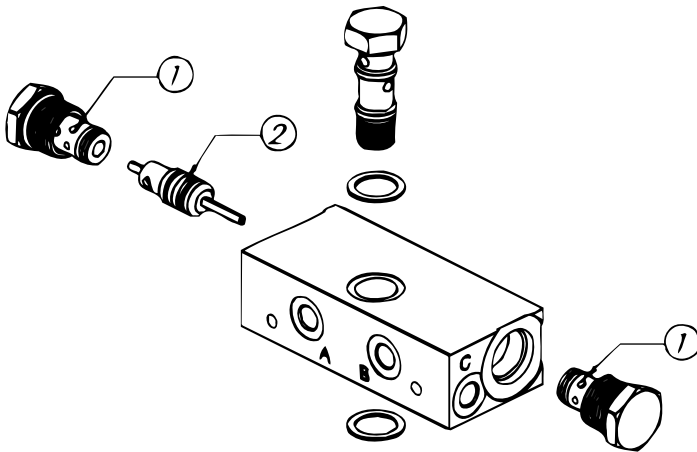
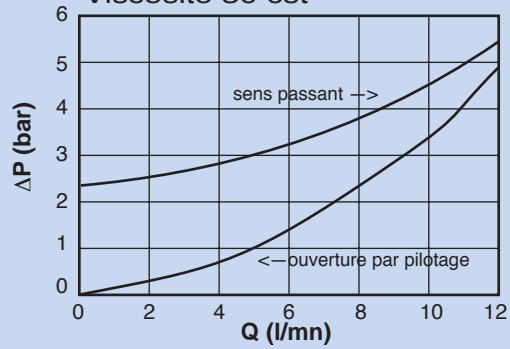

Repère Mark TRAD	Cartouche Cartridge Patronen	Pochette joints Seal kit Dichtungssatz
1	D02B2-2.1N	SK30515N
2	PP12025	

