

## Checkball Piston Pumps For Water Glycol Fluids

**PF4300 SERIES**  
1.9 to 6.6 gpm (7,2 to 25,0 L/min) at 1800 rpm  
10 000 to 15 000 psi (700 to 1040 bar)

PF4300 Series pumps are compatible with a wide range of fluids including water-glycol, diesel calibration fluid, Skydrol, other phosphate ester fluids, various military fluids and other low-viscosity fluids.

These fixed displacement pumps operate at maximum pressures from 10 000 psi (700 bar) to 15 000 psi (1040 bar).

### SPECIAL FLUID APPLICATIONS

High pressure capability and compatibility with water glycol make these pumps ideal for use in off-shore blowout preventer (BOP) and production control systems.

They are also well suited for development or production test-stands, aircraft ground support equipment and other applications using special fluids.



*Checkball pumps are single fluid pumps with bearing lubrication provided by the pumped fluid. This eliminates the potential for fluid cross contamination, possible in other pump designs with isolated bearing lubrication. This design also eliminates the need for a separate lubrication circuit or regular maintenance of a lubricating oil.*

### IMPROVED WEAR AND EFFICIENCY

These pumps use piston check valves to direct flow from the pump inlet to the outlet. The check valves take the place of a valveplate, commonly used in other pump designs.

The metal-to-metal rotating sealing surface in other pumps is an inherent leak path, subject to wear when



operating with lower-lubricity and other special fluids. The positive-seating action of the check valves provides better wear and greater volumetric efficiency, especially with lower-viscosity fluids and higher pressures.

### CORROSION RESISTANT

The pump housing and barrel assembly are treated for corrosion resistance. The outlet port block is made of stainless steel. The pumps are shipped unpainted, ready for customer application of the final protective coating.

### PUMP SELECTION

Refer to page 4 for options and complete model code for ordering.

The table indicates maximum pressures for models with the high pressure "H" option. This option is required when operating at pressures higher than 8000 psi (560 bar). It requires the use of outlet port option "A" (Autoclave Medium Pressure, Butech M/P or equivalent fitting) or "B" (British Standard Pipe fitting).

For operation at lower pressures, ports are available for use with standard S.A.E. fittings.

### SPECIFICATIONS

Pump Model	Output Flow <sup>①②</sup>						Maximum Pressure		Rated Speed rpm	Maximum Speed rpm <sup>②</sup>
	1200 rpm		1500 rpm		1800 rpm					
	U.S. gpm	L/min	U.S. gpm	L/min	U.S. gpm	L/min	psi	bar		
PF4303H-10	1.3	4,8	1.6	6,2	1.9	7,2	15 000	1040	1200	1800
PF4304H-10	2.0	7,6	2.5	9,5	3.0	11,4	12 000	840	1200	1800
PF4305H-10	2.3	8,9	2.9	11,0	3.5	13,3	10 000	700	1200	1800
PF4308H-10	3.4	13,1	4.3	16,4	5.2	19,6	10 000	700	1200	1800
PF4309H-10	3.9	14,7	4.8	18,2	5.8	22,0	10 000	700	1200	1800
PF4310H-10	4.4	16,7	5.5	21,0	6.6	25,0	10 000	700	1200	1800

① Output flow based on typical performance at maximum pressure with pressurized inlet where required.

② Consult the Dynex sales department for operation above the rated speed of 1200 rpm.

# Installation and Operating Data

## OPERATING RECOMMENDATIONS

Consult the Dynex sales department for applications which require operating above rated pressures, speeds or normal temperatures.

### Fluid

Because of the wide range of fluid characteristics, please contact the Dynex sales department for a review of your application.

For applications using standard petroleum-based fluid, request information on Dynex PF4200 Series pumps. These pumps provide similar flows at maximum pressures to 20 000 psi (1380 bar).

### Seal Options

Seal options include Fluorocarbon (*Viton®* or *Fluorel®*) or EPR for use with some phosphate ester fluids. High pressure shaft seals are standard on all models.

### Inlet Conditions

Pumps may require pressurized inlet conditions at elevated speeds. Failure to meet inlet requirements will result in flow reduction. See the "Minimum Inlet Pressure" table above.

### Minimum Filtration Levels

Pump inlet, 150  $\mu$  nominal;  
Pressure or return line, 25  $\mu$  nominal;  
Finer filtration levels than these are desirable and will result in longer component life. Restricting flow to the pump inlet should be avoided.

## MINIMUM INLET PRESSURE

Pump Model	Operating Speed <sup>①</sup>					
	1200 rpm		1500 rpm		1800 rpm	
	psi	bar	psi	bar	psi	bar
PF4303	0	0	0	0	0	0
PF4304	0	0	0	0	0	0
PF4305	0	0	0	0	0	0
PF4308	0	0	0	0	5	0,4
PF4309	0	0	5	0,4	10	0,7
PF4310	0	0	5	0,4	15	1,0

① Consult the Dynex sales department for operation above the rated speed of 1200 rpm.

## Drive Shaft Rotation

These fixed displacement pumps are bi-directional, allowing drive shaft rotation in either direction without changing the direction of flow.

## INSTALLATION AND DIMENSIONS

All dimensions are shown in inches (millimeters in parentheses) and are nominal.

The drawing shows dimensions common to all PF4300 Series pumps. Note, however, that Model PF4303 has three pistons, rather than five.

As shown, the outlet port on these pumps is machined in a stainless steel block integrally mounted to the pump barrel.

Refer to the "Typical Model Code" on page 4 for selecting port options.

The mounting for all PF4300 Series pumps is directly interchangeable with Dynex PF4200 Series models.

## Orientation

Generally, shaft horizontal with inlet vertically up. Consult the Dynex sales department for applications requiring vertical shaft-up mounting or inlet orientation other than vertically up.

## Mounting

S.A.E. D 4-bolt pattern with 0.25 inch (6,4 mm) pilot engagement; 1.250 inch (31,75 mm) diameter keyed shaft.

## Optional Spline Shaft

1.248/1.247 inch diameter standard S.A.E. 14 tooth, 12/24 D.P. 30° involute spline.

## Weight (Mass)

116 lb (53 kg)

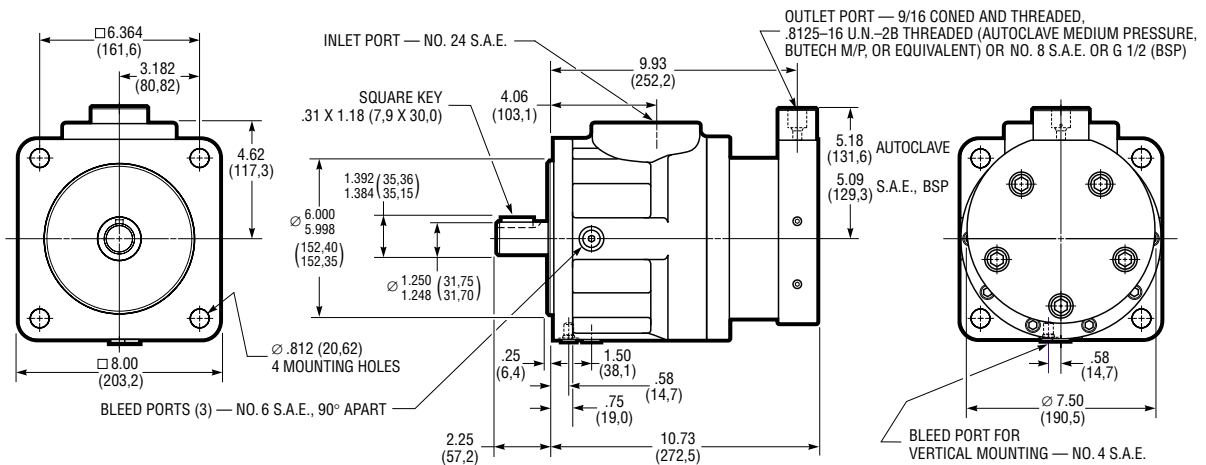

**TYPICAL PERFORMANCE CURVES ①②**

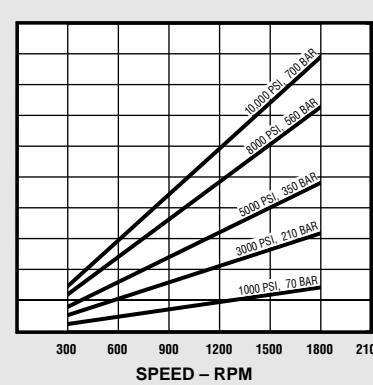
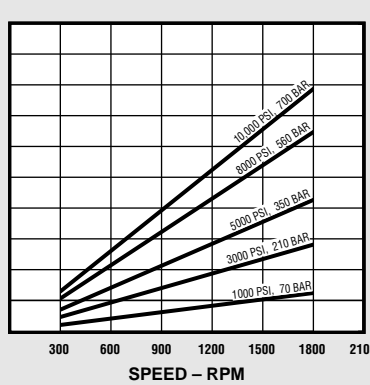
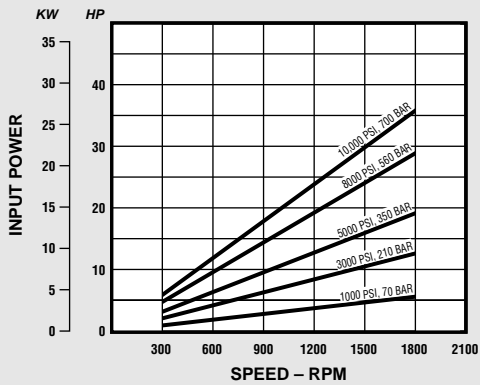
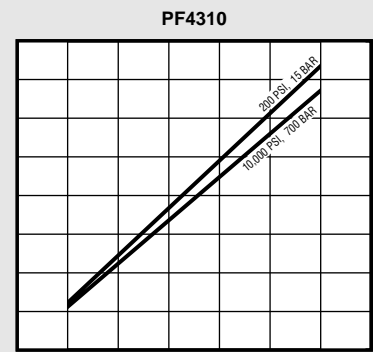
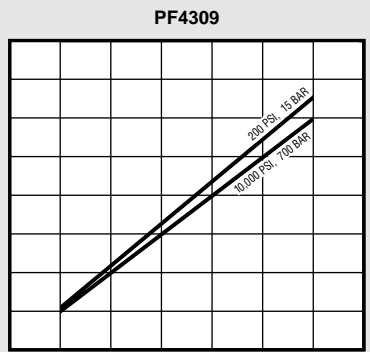
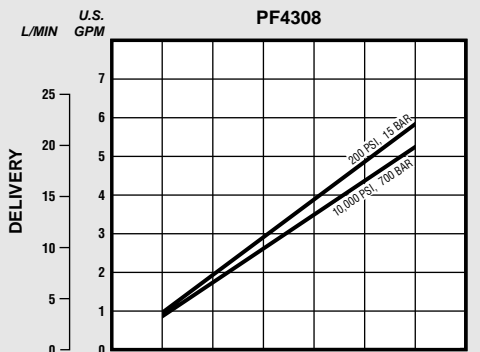
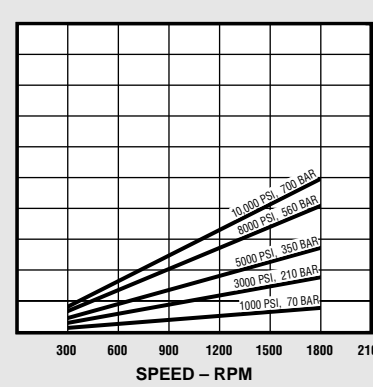
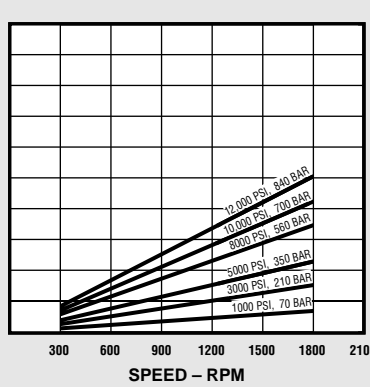
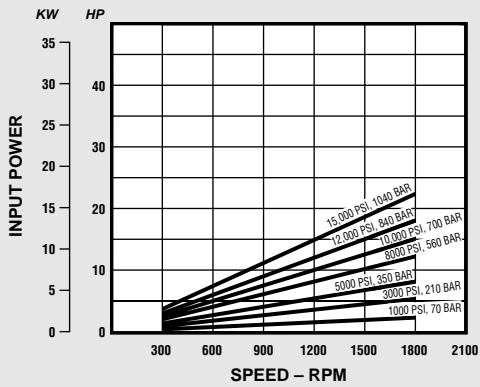
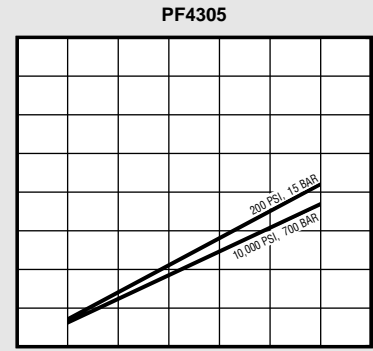
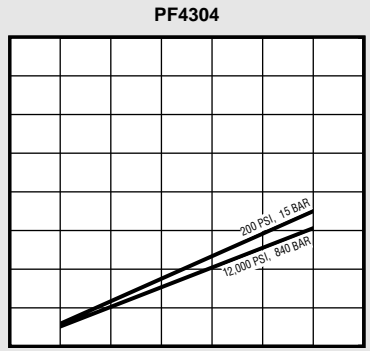
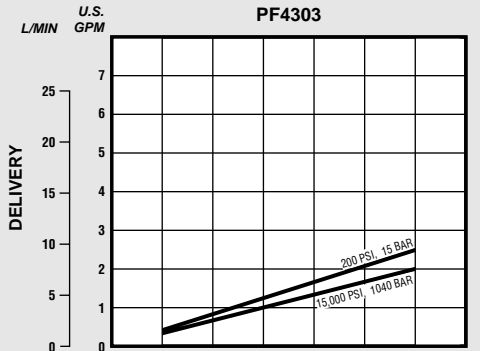

① Typical performance curves are based on 33 SUS (1,9 cSt) Oceanic HW443 fluid at 105° F (40° C) with pressurized inlet where required.  
 ② Consult the Dynex sales department for operation above the rated speed of 1200 rpm.

# Typical Model Code

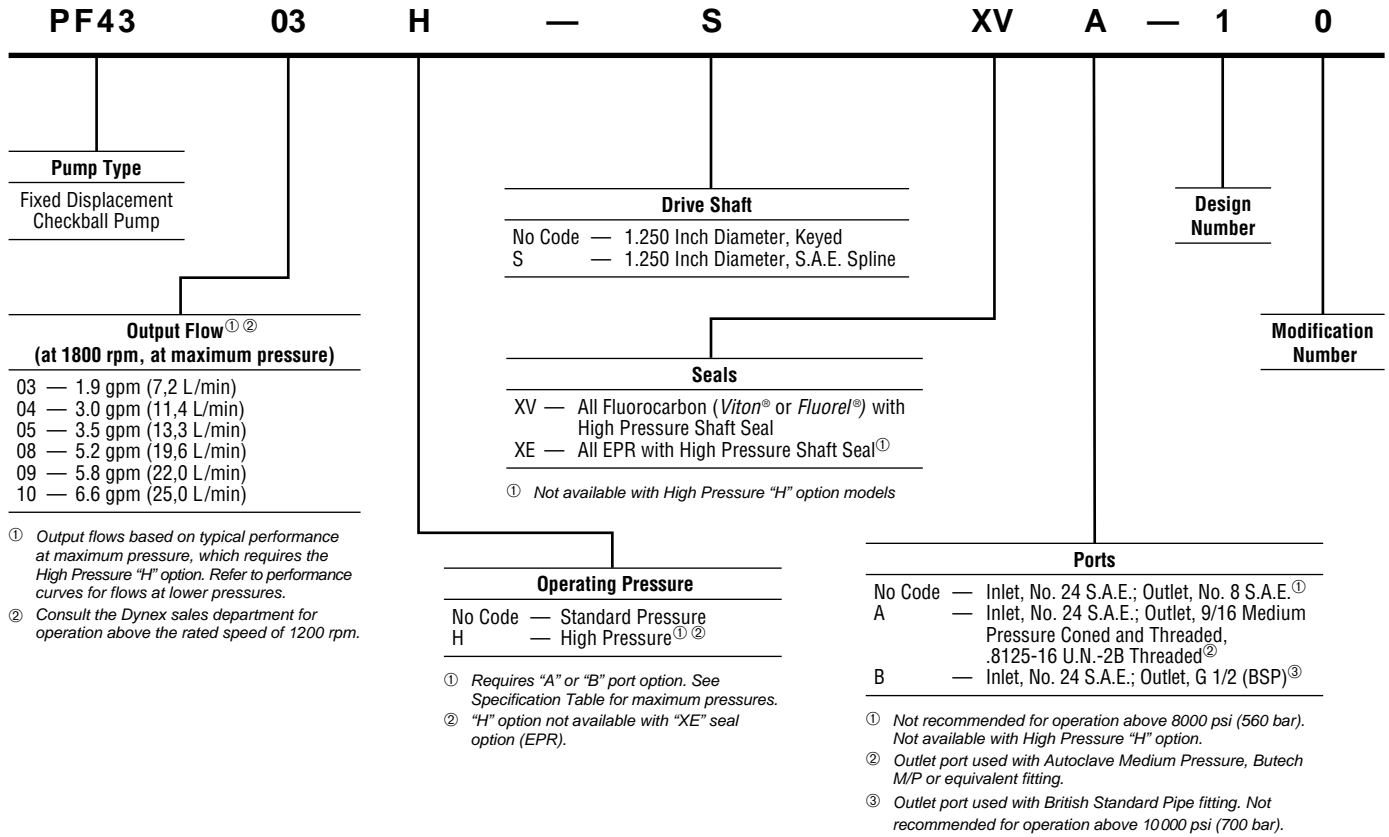

<sup>①</sup> Output flows based on typical performance at maximum pressure, which requires the High Pressure "H" option. Refer to performance curves for flows at lower pressures.  
<sup>②</sup> Consult the Dynex sales department for operation above the rated speed of 1200 rpm.

For more information  
 visit our web site:  
[www.dynexhydraulics.com](http://www.dynexhydraulics.com)

<b>USA Headquarters</b> Dynex/Rivett Inc. 770 Capitol Drive Pewaukee, WI 53072 U.S.A. Tel: 262-691-2222 FAX: 262-691-0312 E-mail: sales@dynexhydraulics.com	<b>Power Units &amp; Systems</b> Dynex/Rivett Inc. 54 Nickerson Road Ashland, MA 01721 U.S.A. Tel: 508-881-5110 FAX: 508-881-6849 E-mail: ashland@dynexhydraulics.com	<b>European Sales</b> Dynex/Rivett Inc. Unit C5 Steel Close, Little End Road, Eaton Socon, Huntingdon, Cambs. PE19 8TT United Kingdom Tel: +44 (0) 1480 213980 FAX: +44 (0) 1480 405662 E-mail: sales@dynexhydraulics.co.uk
---	---	--