

VALVE D'EQUILIBRAGE SIMPLE	Montage banjo	HCP 2B
SINGLE LOAD CONTRAL VALVE	Screwed mounting	

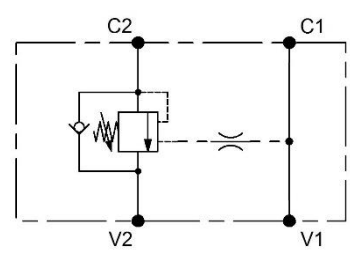
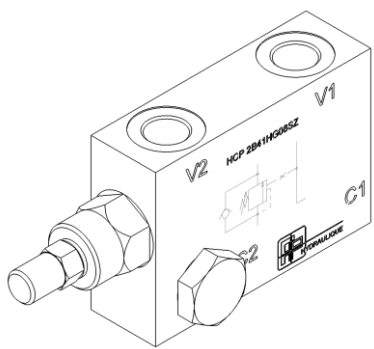

Codification	Identification code							
	<table border="1" style="margin-left: auto; margin-right: auto;"> <tr> <td style="text-align: center;">HCP</td> <td style="text-align: center;">2B</td> <td style="text-align: center;">41</td> <td style="text-align: center;">H</td> <td style="text-align: center;">G08</td> <td style="text-align: center;">S</td> <td style="text-align: center;">Z</td> </tr> </table>	HCP	2B	41	H	G08	S	Z
HCP	2B	41	H	G08	S	Z		
Ratio de pilotage <i>Pilot ratio</i> 41 = 4,5 : 1								
Matière joints <i>Seals material</i> H = Nitrile								
	Raccordement <i>Line fitting size</i> G08 = 3/8" Gaz cylindrique							
	Fonction <i>Function</i> S = Simple / single							
	Réglage <i>Adjustement</i> Z = Vis / screw							

Consignes de fonctionnement	Operating indications
<p>Cette valve d'équilibrage permet le maintien et le contrôle d'une charge menante. Pour assurer un bon fonctionnement, elle doit être utilisée avec un distributeur centre A et B vers T au repos.</p> <p><i>This load control valve is used to maintain a load, control moving load and prevent load runaway. To ensure the load control function, the A and B ports of the directional valve must be connected to T in the center position.</i></p>	
<p>Pc = Pression induite par la charge / <i>Pressure induced by load</i> Po = Pression de pilotage nécessaire à l'ouverture / <i>Cracking pressure</i> Pr = Pression de tarage / <i>Setting pressure</i></p>	$P_o = \frac{P_r - P_c}{\text{ratio de pilotage}}$
<p>La valve devra être tarée à environ 30% de plus que la pression maximum engendrée par la charge. <i>The valve should be set about 30% above the maximum pressure induced by load.</i></p>	

Caractéristiques

Features

Raccordement / Line fitting size	G08
Débit maximum / Maximum flow rate (L/min)	40
Pression maximum / Maximum pressure (bar)	350
Ratio de pilotage / Pilot ratio	4,5:1
Masse / Weight (kg)	1,3
Degré de contamination du fluide Fluid contamination degree	Selon ISO 4406 : Classe 20/18/15

Courbes de pertes de charge (température d'huile : 50°C ; viscosité : 30 cSt)
Pressure drop curves (oil temperature : 50°C ; viscosity : 30 cSt)

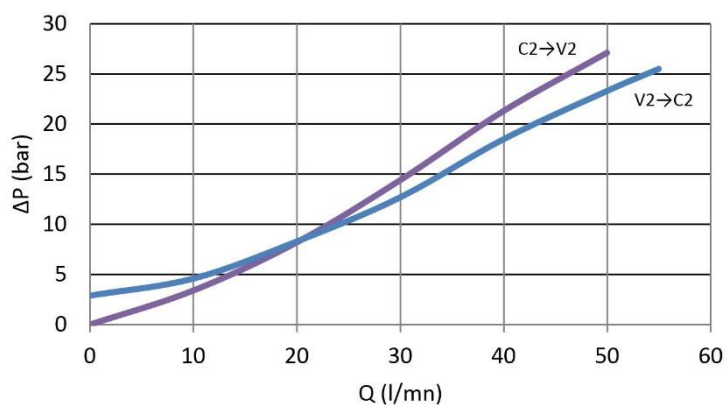

Encombrement

Overall dimensions

